

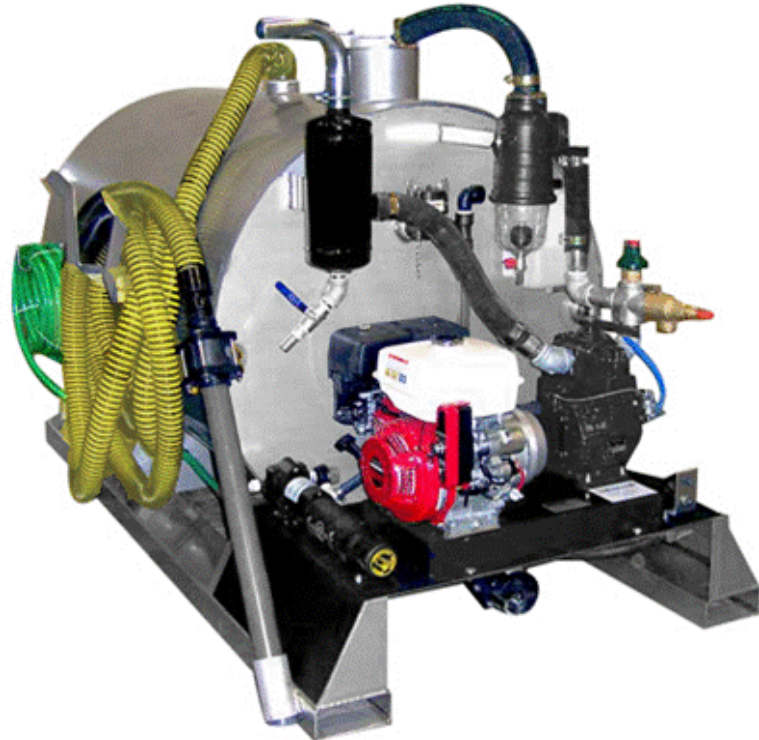

WARNING: Study this manual before operating or maintaining your slide-in vacuum tank and any of its components. You must understand and follow the instructions in this manual; otherwise you and/or others can be seriously injured. DO NOT operate this equipment if you have not read and understood all of the safety and operating instructions. Also, DO NOT allow any other person to operate this equipment if they have not read and understood all of the safety and operating instructions.



SLIDE-IN VACUUM TANK OPERATOR'S MANUAL

Date of Purchase: _____

Tank Model: _____

Tank Serial Number: _____

The manufacturer reserves the right to change specifications or make improvements without notice and without incurring obligations to products previously sold. Information contained herein is from data available at time of printing.

TO THE PURCHASER

Congratulations on your purchase of a Satellite product. Your slide-in vacuum tank will give you years of dependable service if the proper operating and maintenance instructions are observed. We recommend that you read this manual carefully to become thoroughly familiar with your slide-in equipment prior to operation.

This manual contains sections on safety, setup, specifications, operation, maintenance, and trouble shooting. Each section in this manual is clearly identified to help you easily find the information you need.



The safety alert symbol will identify important safety messages. When you see this symbol, carefully read the message that follows.

The information in this manual covers all Slide-in Vacuum Tanks. It is important to record your tank model number, tank serial number, and date of purchase in the spaces provided on page 1. This information will be useful to your dealer when ordering parts for repair.

Your vacuum tank warranty appears on the last page of this manual. Please read it carefully, making sure you understand the warranty coverage as well as its exceptions and limitations.

TO THE PURCHASER





SAFETY PRECAUTIONS

Throughout this manual, and on machine decals, you will find precautionary statements followed by specific instructions. In the interest of safety, take the time to learn these precautions.

Precautionary statements dealing with personal safety are preceded by the signal words DANGER, WARNING, and CAUTION. These precautions are intended for your personal safety and for the safety of those working with you.

 **DANGER:** Indicates a hazard or unsafe practice that, if not avoided, will result in death or serious injury.

 **WARNING:** Indicates a hazard or unsafe practice that, if not avoided, could result in death or serious injury.

 **CAUTION:** Indicates a hazard or unsafe practice that, if not avoided, will result in death or serious injury.

machine safety are preceded by signal words **NOTICE** and **IMPORTANT**. These precautions are intended to help protect against damage to your equipment and to inform operators of helpful information.

▶ **NOTICE:** Indicates a possibly dangerous situation that, if not avoided, could result in damage to equipment.

■ **IMPORTANT:** Indicates helpful information on operation of equipment.

Precautionary statements dealing with

GENERAL SAFETY PRECAUTIONS

Follow these safety precautions, and insist that those working with you follow them.

Most industrial equipment accidents can be avoided by observing safety precautions.

Remember: a careful operator is the best insurance against an accident.

Safety Precautions for Handling Effluent

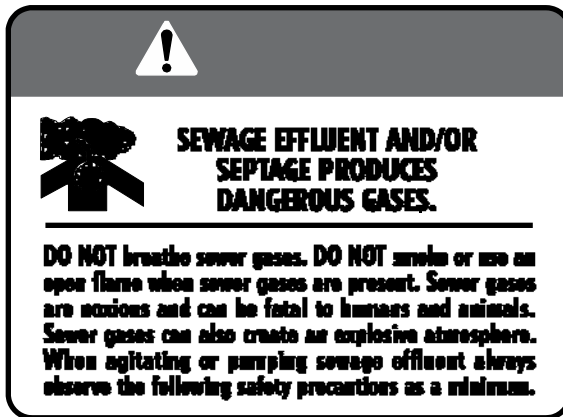

⚠ DANGER: DO NOT stand near the oil catch muffler or discharge valve when loading or unloading the tank. Sewer gases vented out of the oil catch muffler will settle downward. Sewer gases can also be expelled out of the discharge valve when releasing tank pressure. Inhaling sewer gases can cause severe injury or death.

⚠ WARNING: DO NOT allow children or irresponsible people or unauthorized persons near your work area or equipment. Make certain everyone is clear of the truck and the immediate area before starting the engine, engaging power, and operating the equipment. The inherent hazards of septic pumping can cause serious injury or death to untrained persons that enter this area.

⚠ WARNING: Sewage and wastewater contain bacteria, fungi, parasites, and viruses that can cause disease. While handling sewage or waste water effluents, sewage workers may be exposed to a variety of these disease causing organisms including, but not limited to: E-coli, hepatitis A virus (HAV), salmonella typhi (which can cause typhoid fever), shigella (which can cause dysentery) and parasitic protozoa and worms (such as *Giardia lamblia* and roundworm).

Proper work practices and personal protective equipment (PPE) can help protect you from becoming infected by these agents. When handling sewage and/or wastewater effluents, or after contact with surfaces exposed to them, observe the following recommendations (as a minimum) regarding work practices and PPE-s:

- DO NOT eat, drink, or smoke while you are working with, or in the area of, sewage effluent.
- Wash your hands thoroughly with clean water and soap before eating, drinking, or smoking and at the end of your work day.

The Portable Sanitation Association International (PSAI) recommends rubbing your hands together for at least ten to 15 seconds after you have worked up a good lather with the soap. The friction of rubbing your hands together loosens bacteria from your skin and traps them in the lather to be rinsed down the sink.

- Use personal protective equipment such as coveralls or water-resistant suit, water-proof gloves and boots, respirators, safety glasses, goggles, and face shields.
- Properly store, clean, or dispose of contaminated personal protection equipment.

- Keep all cuts and wounds covered with clean, dry bandages and protect them from exposure to sewage effluent.
- Change out of your work clothes and boots before leaving work; DO NOT wear them home. DO NOT keep your soiled work clothes with your other or your families' clothes. Wash your work clothes separately in hot water.
- Both the CDC (Center for Disease Control) and the Building and Construction Trades Dept. of the AFL-CIO recommend that sewage workers maintain up-to-date tetanus-diphtheria immunizations to counter the risk of soil-contaminated injuries.
- While studies in Scandinavia, England, and the United States have not found a substantial increase in the prevalence of HAV among sewage workers (CDC publication: MMWR, Vol. 48, No. RR-12), stay abreast of any Hepatitis A outbreaks in your area, and contact your doctor about a vaccination should you have any concerns about coming in contact with this virus.
- While the fecal coli form bacteria E-Coli has been regarded mainly as a food-borne illness, contact with farm animals and contaminated water have arisen as other sources of infection. In a number of cases, water supplies were contaminated due to runoff from structures such as septic systems and agricultural manure lagoons that contain human and animal fecal material respectively.

For example, a CDC survey after the Midwest floods of 1993 found E. coli in 11.1% of the samples collected from more than 5500 domestic wells. In identifying potential contamination sources within 100 feet of the wells, the CDC found 47.1% of it coming from septic systems, according to Homer Emery, Ph.D., in Coli form bacteria, biosolids and health risks, October 2000, the Pumper.

Knowing that E-Coli can be present in

sewage effluent needs to provide a clear signal to sewage workers to wear PPEs and wash hands thoroughly before eating, drinking, or smoking.

- In addition, even though public concern remains high, the blood-borne viruses Hepatitis B and HIV (Aids) have not been linked in the U.S. to exposure to sewage - according to the hazard alert released by the Center to Protect Workers' Rights (which is the research and development institute of the Building and Construction Trades Dept., AFL, CIO) titled Biological Hazards in Sewage and Wastewater Treatment Plants ©2000.
- Finally, as more data is collected on biohazards, and as new biological threats emerge, it is your responsibility as a waste industry worker to remain educated about the hazards involved in working with sewage and wastewater effluents. Several sources for obtaining up-to-date information are listed below:

National Center for Infectious Diseases (NCID) at (www.cdc.gov/ncidod) National Institute for Occupational Safety and Health (NIOSH) at (1-800-35-NIOSH or www.cdec.gov/niosh)

OSHA (1-800-321-OSHA or www.osha.gov)



WARNING: Always wear protective gloves, eye protection and, appropriate clothing when working with sewage effluent or septage. These materials may contain hazardous chemicals and bacteria, which can cause infection, injury, or even death due to contact.

Safety Precautions for Conned Spaces



WARNING: DO NOT reach into the tank for cleaning without protective clothing. Sewer gas can be absorbed through the skin causing serious injury.

⚠ WARNING: DO NOT attempt to enter the tank of a portable slide-in unit. The hatch provided on some tanks is intended to provide reach-in access for cleaning only. DO NOT place your face or head into the tank when reaching into it. These tanks are not designed to permit entry, and any attempt to enter them could result in serious injury or death.

Safety Precautions for Operating Equipment

⚠



VACUUM TANK OPERATION INVOLVES POTENTIAL HAZARDS

Personal injury may result if certain safety precautions are not followed while operating vacuum tanks. While these may not cover all possible hazardous situations, carefully learn and observe the following safety precautions as a minimum.

⚠ DANGER: Stop the truck motor, remove all persons from the truck cab, and chock the truck tires before servicing any of the components on your slide-in unit. A truck that begins to roll is a crushing hazard that can lead to death.

⚠ DANGER: Make sure the gas engine on your slide-in unit is shut off before servicing the vacuum pump. Contact with a rotating mechanism can cause entanglement that can lead to death.

⚠ WARNING: Keep hands, feet, hair, and clothing away from moving parts. Contact with a moving mechanism can cause entanglement that can lead to dismemberment or death.

⚠ WARNING: Keep all shields in place. Shields and covers are designed to protect the operator from entanglement in moving parts, which can lead to serious injury or death. DO NOT remove shields from the unit except when servicing; then replace immediately.

⚠ WARNING: The truck's cornering and braking abilities are reduced when the tank is loaded. Drive at a reasonable speed with a loaded tank; reduce speed on rough or hilly terrain, before making an anticipated stop, and when cornering.

⚠ WARNING: DO NOT allow anyone to ride in the bed of the truck when the slide-in unit is installed in it. Failure to follow this precaution could result in persons falling off the truck and possibly getting run over, which could cause serious injury or death.

⚠ WARNING: Before backing-up the truck, inspect the area to be backed into, and clear all hazards, pets, and people from it.

⚠ WARNING: When off-loading under pressure, maintain control of the end of the hose. Pressurized discharge can cause a hose end to whip about and create the potential for spraying persons in the area with effluent.

⚠ WARNING: Avoid contact with the vacuum pump during or immediately after operation. Operating temperatures can range from near 200°F to over 300°F, depending on the make and model of pump and on the working conditions. Contact with a hot vacuum pump can cause severe burns.

SPECIFICATIONS

General SPECIFICATIONS FOR YOUR PORTABLE SLIDE-IN UNIT ARE LISTED IN Table 2.1 below. All dimensions are given in inches.

Table 2.1 Slide-in Specifications

Model	S-300	S-550
Gallon Capacity	200/waste 100/fresh	370/waste 270/fresh
Overall Length	71"	109"
Skid Width	48"	48"
Overall Height	61"	61"
Empty Weight	1,500 lbs.	1,800 lbs.
Loaded Weight	3,367 lbs.*	4,601 lbs.*
Engine	Honda GX240 - 9.0 h.p.	Honda GX240 - 9.0 h.p.
Vacuum Pump	HXL3V	HXL3V
Conde Model 6		
Water Pump	WHALE 4300 - 4.9 g.p.m.	Flojet 4300 - 4.9 g.p.m.
Inlet Coupling	2" Cam Lock	2" Cam Lock
Outlet Coupling	3" Cam Lock	3" Cam Lock

*Note: Loaded weights are based on a full septic compartment and a 1/4 full fresh water compartment (under normal operating conditions, both compartments will not be full at the same time).

SPECIFICATIONS

**This diagram for 300 and 450 modules, 550 does not fit in pickup.

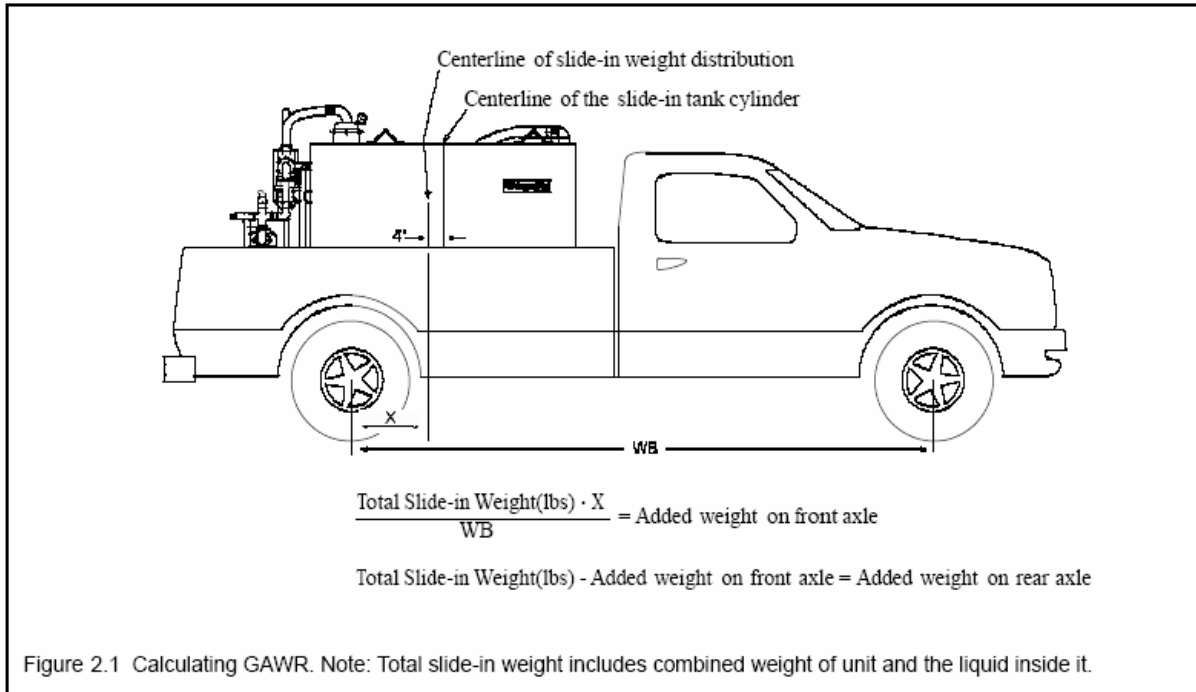

SETUP

SET UP

Your portable slide-in unit comes assembled from the factory. The slide-in unit is ready to put into use when you receive it, aside from some necessary owner setup. This includes lifting the unit into your truck bed, securing it to prevent shifting, connecting the battery cable in order to start the engine, and installing the vacuum/pressure gauge.

Vehicle Weight Requirements

Before setup, be sure that the truck you use to carry your slide-in unit has a Gross Vehicle Weight Rating (GVWR) and a Gross Axle Weight Rating (GAWR) high enough to handle the combined weight of the slide-in unit and the liquid inside it.

Exceeding the GVWR or GAWR of your truck could damage it. More importantly, exceeding these ratings could impede your ability to brake safely. In addition, federal DOT regulations prohibit a vehicle that exceeds its GVWR or GAWR from

operating on public roadways.

The GVWR of your truck minus its base weight equals the total vehicle payload that can be carried. The surest way to verify the maximum payload a given vehicle can carry is to begin by having your truck weighed at a certified scale.

As a note of caution, the advertised payload weight for a particular truck may not be the actual load that you can carry with your truck.

Advertised payloads often don't take into account the weight of options such as automatic transmissions that can add up to 100 pounds to your vehicle. In addition, the advertised payloads may not take into account the weight of passengers and gear (such as tools) being carried by the truck. Ignoring these factors could result in your truck being found to be overloaded during a roadway weight inspection.

A certified scale can provide an accurate base weight of your vehicle, accounting for all of the weight varying factors.

Once the base weight of the vehicle is known, subtract this from the GVWR of your truck to give the payload weight that can be carried. The payload capacity must be equal to or greater than the weight of the slide-unit (and all liquid inside it) that you wish to carry. Loaded and unloaded weights of the various Slide-in units can be found in the specifications table on page 7.

To determine if the GAWR of your truck can handle the load of a liquid filled slide-in unit, first, obtain the weights of the vehicle with just the front tires on the scale and then with just the rear tires on the scale. Note that for these weights to be accurate, the approach and exit to the scale must be level with the scale surface. An inclined approach will shift the weight toward the rear axle when the front wheels are on the scale, skewing the weight readings.

Next, take measurements to determine where the slide-in unit will be positioned in the truck bed. With the position of the unit determined, measure the center of weight for the slide-in as per Figure 2.1. Use this measurement in the formula in Figure 2.1 to calculate the additional weight that will be added to each axle when carrying your slide-in unit (reference the loaded and unloaded weights of the slide-in units in the specifications table on page 7). The scaled weight plus the added weight provided by the slide-in unit must remain with the GAWR.

⚠ WARNING: DO NOT exceed the Gross Vehicle Weight Rating (GVWR) or the Gross Axle Weight Rating (GAWR) for your vehicle when carrying your portable slide-in unit. Exceeding the GVWR or the GAWR of your vehicle can cause damage to the vehicle and can impede the braking performance of the vehicle causing traffic accidents and serious injury or death to others.

Lifting Unit into Truck

Use hoist with at least a one (1) ton capacity rating to lift your slide-in unit into truck bed. To rig for lifting, fasten the hoist chains to the built-in lift hooks on the slide-in unit (Figure 2.2).



Figure 2.2 Hoisting Slide-in Unit for Installation in truck bed

Securing Unit to Prevent Sliding

After lifting the slide-in unit into the truck bed, fasten it securely to prevent sliding. If allowed to slide, the unit can wear on the bed floor and/or crash into, and break, the tailgate. Satellite Industries recommends that you use the optional Mounting kit to fasten your slide-in unit through the truck bed to the truck frame.

The slide-in mounting kit requires that holes be drilled into the frame of the truck. Because the frame is the backbone of the truck, proper frame integrity must be maintained when attaching components or equipment.

Observe the following precautions when making any alterations to your truck frame:

- Avoid applying heat to the frame with a torch or any other such equipment.
- Avoid welding on the frame.
- DO NOT use a torch to cut holes into the frame.
- DO NOT cut notches in the frame rails.
- DO NOT drill holes in the frame rail

flanges; drill holes only in the web area of the frame

- New holes should be drilled as close as possible to the neutral axis of the web (halfway between the flanges) or on the same horizontal line as adjacent holes.

If you have any questions or concerns about drilling the frame for bracket attachment on your particular truck, consult your local truck dealership. In addition, most truck manufacturers publish a body builder's guide that contains specific recommendations for frame alteration. Your dealership should be able to help you obtain this guide.

Following all relevant precautions, use the procedure below, while referring to Figure 2.3, to install the mounting kit:

- Determine an area of the frame to which the lower mounting brackets can be bolted. The positioning of these brackets will have to take into account frame braces and other frame mounted components. Place the mounting points as far apart as possible (within the length of the slide-in rails) while locating them in an area with enough space for drilling and bolting through the truck frame.
- Position the brackets against the frame so that the top face of the bracket angle is about level with the top of the frame. Make sure there is adequate clearance between the top of the bracket and the underside of the truck bed to allow for the normal flexing of the truck. After determining the position of the brackets, drill two 11/16" clearance holes in the long leg of each bracket. Then, using the brackets as a template, mark the hole locations, and drill 11/16" dia. clearance holes through the truck frame.
- Bolt the lower brackets to the truck frame using 5/8"-11NC Grade 8 bolts. These bolts are not included in the mounting kit and must be purchased in the correct length for your specific

installation. Use 5/8"-11NC crown-lock lock nuts with these bolts. Fasten the brackets to the outside of the truck frame rails with the short leg of the bracket pointing outward (Figure 2.3).

- Next, using the hole in the short leg of the bracket as a guide, drill an 11/16" dia. clearance hole up through the truck bed. Be careful when drilling up through the thin gage metal of the truck bed. If possible, grind a sheet metal drilling point on the drill bit. Otherwise use a center-drill, and then step your way up to the final hole size using several drill bits.

- The next step involves welding the upper brackets to the slide-in rails. Take the appropriate precautions before performing this welding. This includes making sure the cap on the engine gas tank is affixed tightly, disconnecting the battery terminals, and attaching the ground cable of the welder as close as possible to the area being welded. Be on the alert for spilled gasoline or gasoline fumes. DO NOT weld if either of these is present.

From the top side of the truck bed, confirm the measurements for the hole locations and transfer these to the slide-in unit rails. With the locations verified, clamp the upper brackets to the rails so that the bottom of the short leg face is slightly above level with the bottom of the rail. Make sure there is at least a little clearance between the bracket and the truck bed. Then, weld the upper brackets to the slide-in rails.

- After the top brackets are welded to the rails, lift the slide-in unit into the truck bed using the procedure outlined in the previous section. To finish assembling the mounting kit, place 5/8" bolts, purchased to the correct length for your installation, up through the frame bracket, through the clearance hole in the truck bed, and up through the top bracket.

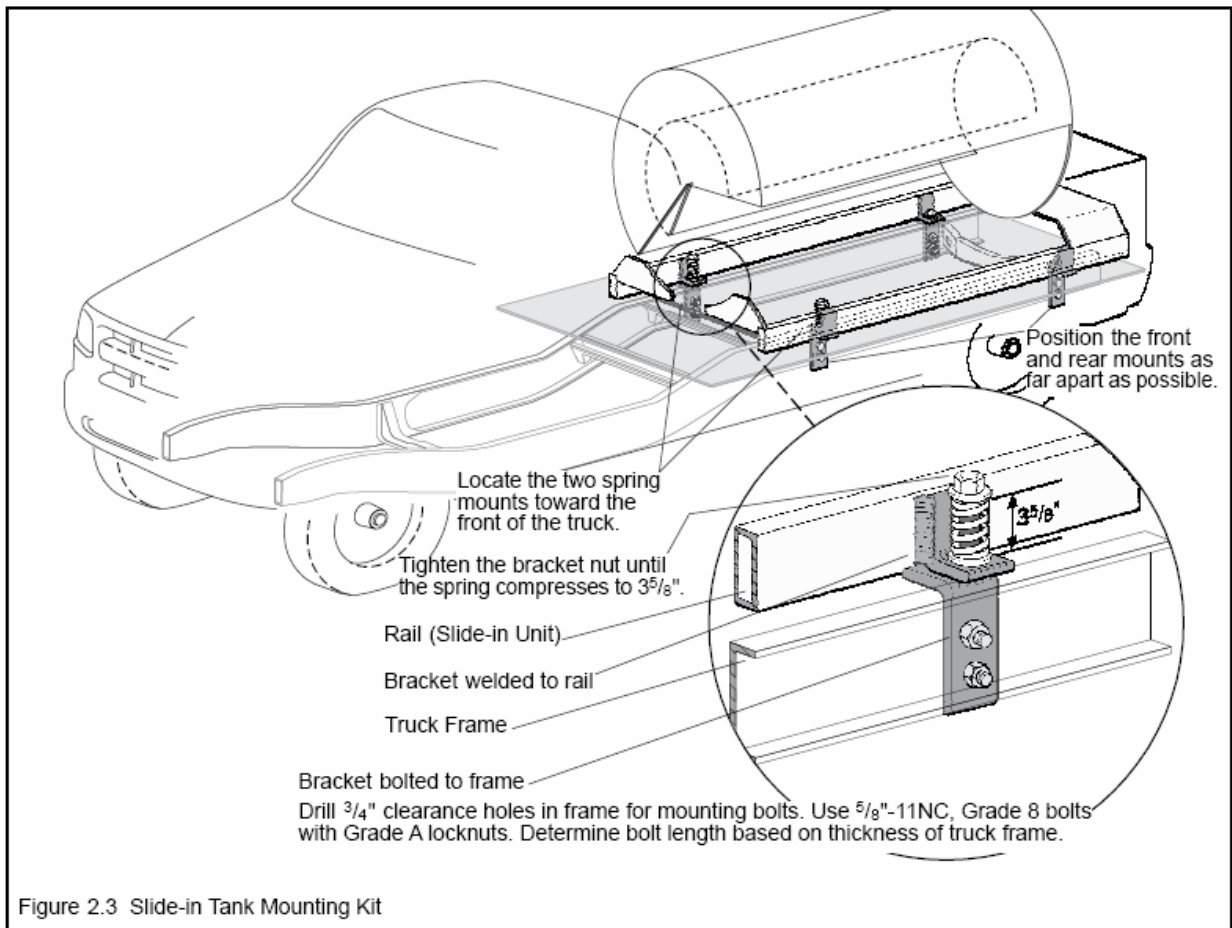

Fasten the two springs included with the kit *over the two front-most bracket bolts* using 5/8" flat-washers and crown-lock lock nuts. Compress the springs to a measurement of 3-8". The rear brackets do not use springs and therefore use a shorter bolt length. Use 5/8" washers and crown- lock lock nuts on these bolts also, and tighten securely.

With your slide-in unit bolted in using the mounting kit brackets, you can now safely transport your unit without the danger of having it slide around in the truck bed. When you need to use your truck for other tasks, simply unbolt the slide-in unit and lift it out of the truck.

⚠ WARNING: Before welding, make sure the cap on the engine gas tank is affixed tightly, disconnect the battery terminals, and attached the ground cable of the welder as close as possible to the area being welded. DO NOT perform

welding if gas fumes are present. Gasoline is highly explosive, and can result in serious injury or death if caused to ignite.

⚠ WARNING: Before transporting your slide-in unit, make sure it is securely fastened into the truck bed in order to keep it from sliding. If not fastened, the unit can crash into and break the tailgate, and possibly fall from the truck causing a traffic accident and/or severe injury or death to persons in the area.

Electrical Setup

Your portable slide-in unit comes with a 12 volt battery for providing power to the electric start gas engine and the motor for the water pump. To make sure the battery maintains its charge, it is disconnected during shipment (Figure 2.4). Connect the battery before placing

your slide-in unit into service. In addition, check the 15 amp system fuse to make sure it has not been damaged during shipment (Figure 2.5).

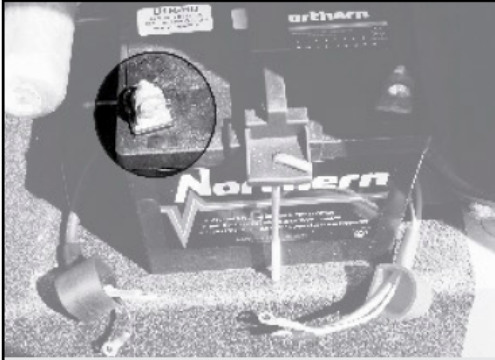

Figure 2.4 Battery Connection



Figure 2.5 System

Vacuum / Pressure Gauge Setup

The vacuum / pressure gauge on your slide-in unit comes disassembled to prevent damage during shipping. Simply thread the gauge into the threaded hole in the gauge cover. Seal the gauge threads by using Teflon tape, Teflon thread sealant, or any other good quality thread sealant.

SETUP

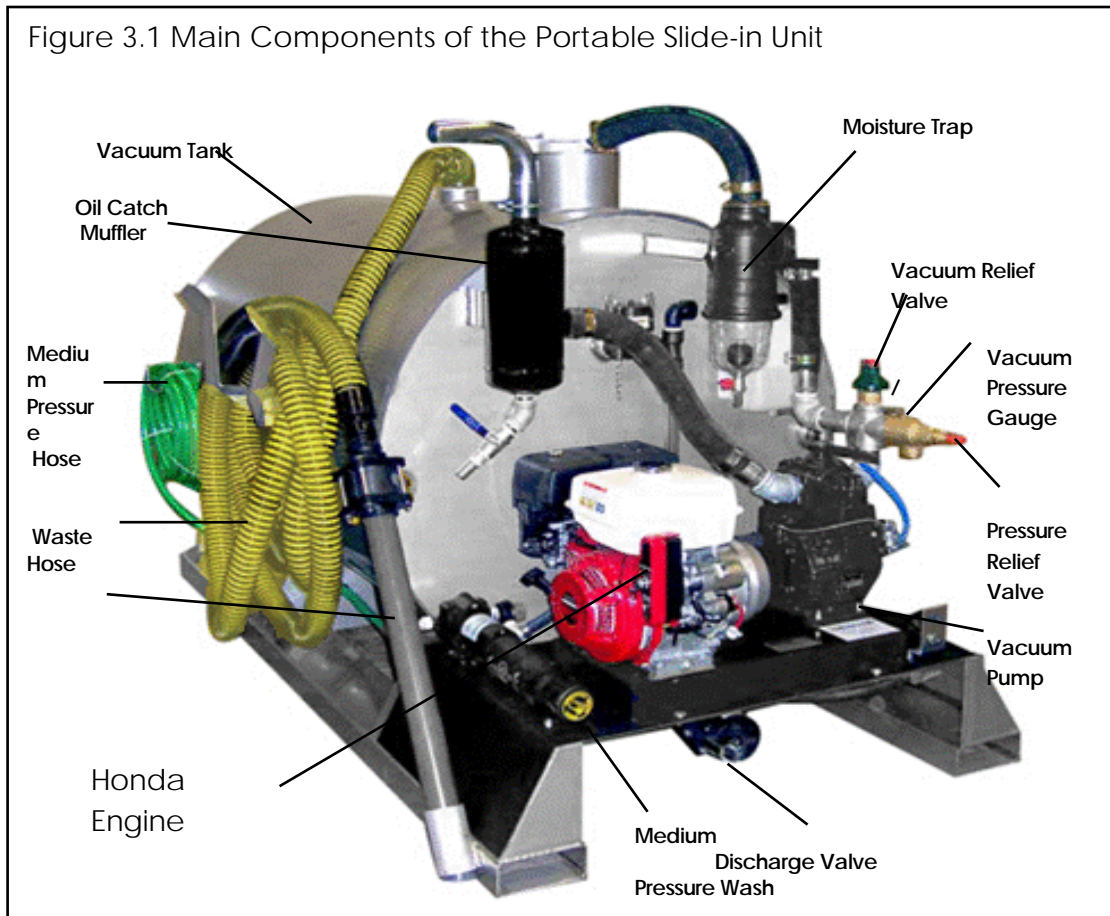

Figure 3.1 Main Components of the Portable Slide-in Unit

OPERATION

The main components of your Portable Slide-in Unit are detailed in Figure 3.1. This illustration provides an introduction to the components on your slide-in that are referred to throughout this manual.

Operation Safety

Operating vacuum tanks, and pumping septic effluent, involves potential hazards. Before operating your portable slide-in unit, you must understand and follow all of the safety precautions in this manual.

Hazards frequently encountered in pumping include dangerous chemicals, exposure to bacteria, explosive atmospheres, falls, high-pressure water jets, rotating drivelines, and poisonous gasses. Because each pumping job is unique, you may experience other hazards as well.

When dangerous situations arise, it is your responsibility to make sure that no harm comes to persons, equipment, or the surrounding environment. Make sure that your job site is secured and safe for others both when you carry out the job and when the job is complete.

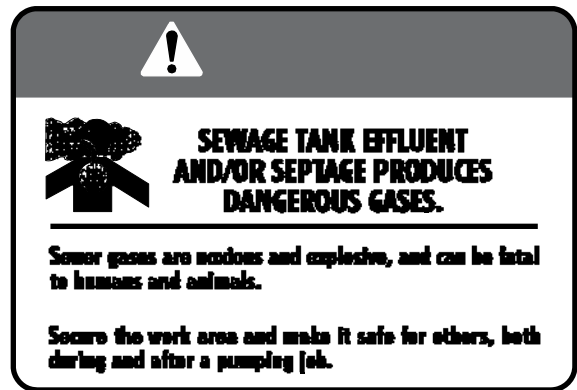
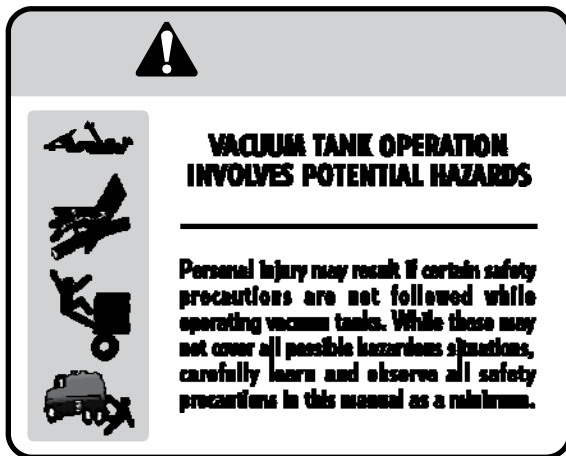

Vacuum Relief Valve

The vacuum relief valve serves to safeguard against vacuum pump damage. It is located in the airline circuit just above the vacuum pump (Figure 3.1). The vacuum relief valve is factory set to 18 Hg. This is the maximum continuous vacuum rating (MCVR) of the vacuum pump. This vacuum level also generates the recommended maximum limit on horsepower draw for the engine.

If you notice that the vacuum relief valve is not relieving vacuum when your tank reaches 18 Hg, you might need to reset it. Use the following procedure to set the valve:

1. Loosen the locking nut located near the top of the vacuum relief valve. Rotate the inner cylinder clockwise one to two revolutions to reduce the setting at which the valve opens. Retighten the locking nut after making the adjustment.
2. Run the pump in the vacuum mode, and check to see if the valve opens at the MCVR as listed above.
3. Repeat steps one and two until you attain the proper setting.

► **NOTICE:** DO NOT run your vacuum pump above the pump manufacturer's maximum continuous vacuum rating. Exceeding the maximum vacuum rating could cause damage to the pump and/or unit.

Pressure Relief Valve

A pressure relief valve is located in the airline circuit next to the vacuum relief valve (Figure 3.1). This valve serves to prevent damage to the tank and motor. It opens, to release air, when the pressure in the tank reaches 6 psi. to 8 psi.

When the pressure relief valve opens to release excess air, it creates a hissing sound that you should be able to hear. Listen for this sound, and if the valve does not open at the above pressure, reset it. Exceeding the recommended 6 psi. to 8 psi pressure can create excessive horsepower draw on your engine causing it to overheat.



CAUTION: DO NOT exceed a maximum pressure of 6 psi to 8psi with your vacuum tank. Exceeding the pressure can create the engine to overheat, which could result in damage to equipment.

Use the following procedure to set the pressure relief valve:

1. Purge all air from the tank by slowly opening the rear dump valve. Stand off to the side of the valve to prevent possible injury from the direct flow of releasing pressure.
2. After purging the tank of air, loosen the setscrew located near the top of the pressure relief valve. Rotate the inner cylinder clockwise one to two revolutions to reduce the setting at which the valve opens. Retighten the setscrew after making the adjustment.
3. Run the vacuum pump in the pressure mode, and check to see if the valve opens at the specified setting as listed above.
4. Repeat steps one through three until you attain the proper setting.

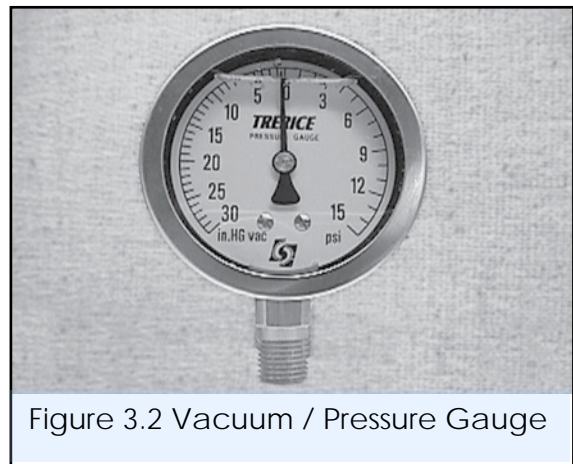

Figure 3.2 Vacuum / Pressure Gauge

Vacuum / Pressure Gauge

A vacuum/pressure gauge is located on your tank (Figure 3.1). As the gauge needle moves counterclockwise of zero, the gauge reads vacuum in inches of Mercury (in.Hg). As the gauge needle moves clockwise of zero, the gauge reads pressure in pounds per square inch (psi) (Figure 3.2). Use the gauge to determine when the tank has reached operating vacuum or pressure.

Moisture Trap (Secondary Shutoff)

The moisture trap (also referred to as the secondary shutoff) serves as a safety device to prevent liquid from entering the vacuum pump. Check the moisture trap daily for accumulation of liquid. Use the easy access drain valve to empty the trap. The drain is located at the bottom of the moisture trap.

While the moisture trap helps prevent liquid from entering the pump, excess accumulation may be an indicator that some contamination has passed into the pump. When excess liquid shows up in your moisture trap, clean your vacuum pump using the procedure on page 25 of this manual.

■ **IMPORTANT:** Anytime that excess liquid accumulates in the moisture trap, clean the inside of your pump. Liquid contamination that enters the pump can

cause damage if you do not clean the pump shortly thereafter.

Oil Catch Muffler

The oil catch muffler collects oil expelled from the vacuum pump and reduces pump noise.

Drain the oil catch muffler daily by opening the drain at the base of the muffler chamber. You may need to drain the muffler more frequently when subjecting the pump to heavy use. Properly dispose of the used oil. **DO NOT** reuse it.

Furthermore, anytime that you notice that water has collected in the oil catch muffler, dry out the vacuum pump interior using the procedure outlined on page 18.

Fill Indicator

Your Portable Slide-in Unit comes with a sight tube and a fill indicator (Figure 3.4). The sight tube displays the liquid level in the freshwater compartment and displays the liquid level in the sewage compartment.

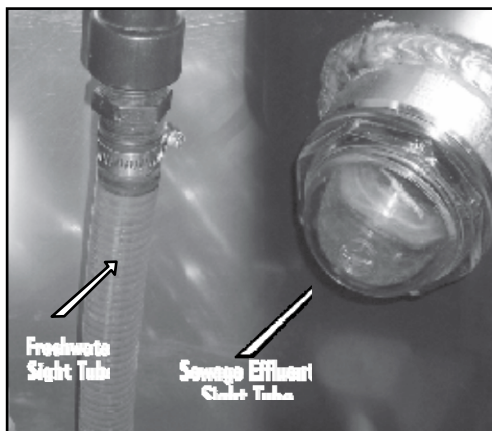

Figure 3.4 Sight Tube Fill

Load and Dump Valves

Your slide-in unit comes with manual load and dump valves (Figures 3.5 and 3.6).

Use the handle mounted to each valve to open and close it.

To allow for easy coupling and uncoupling of the vacuum or discharge hose, both the load and the dump valves are equipped with cam lock-fittings.

There is a cam lock fitting cover for the dump valve. When the discharge hose is uncoupled, place this cover over the dump valve opening to keep dirt and debris from collecting in it.

Because dumping arrangements vary widely from one operation to another, discharge hose is not included with your slide-in unit. Based upon your specific requirements, procure the correct length of 3" discharge hose and a 3" cam lock attachment to couple to the discharge outlet.

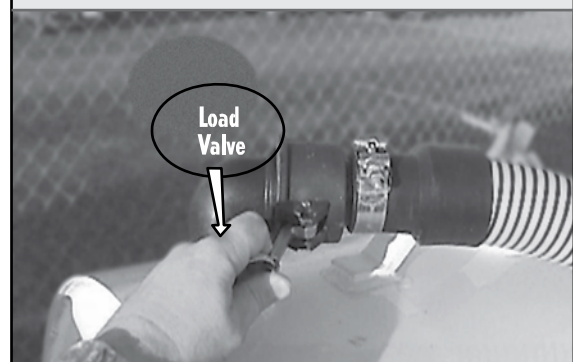
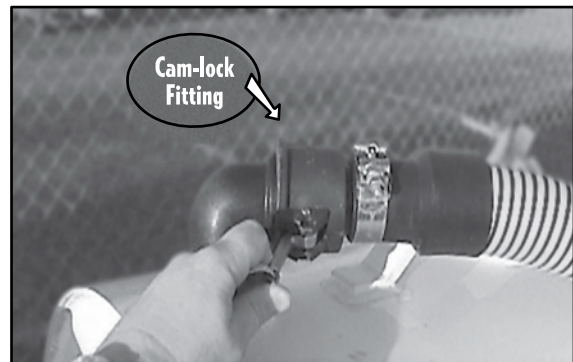

Figure 3.5 Cam lock Coupling & Load Valve (on load hose)

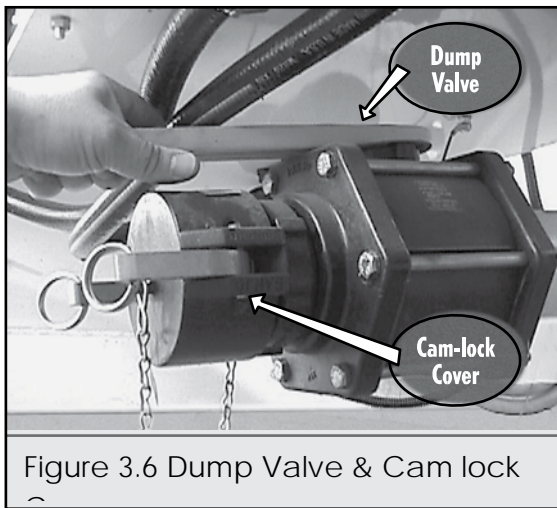

Figure 3.6 Dump Valve & Cam lock

Vacuum Pump

The OEM Operation Manual for your Masport HXL3V or Conde Model 6 vacuum pump is included in the literature packet that you received with your Slide-in Unit. Review and follow the operation procedures outlined in that manual.

Satellite Industries furnishes the following information to provide a better understanding of your vacuum equipment. This information is intended to augment (not replace) the OEM instructions for your pump.

■ **IMPORTANT:** Follow the operation procedures outlined in your OEM pump manual in order to keep your warranty valid and to receive maximum service life from your pump.

Safety Suggestions for Vacuum Pump

WARNING: Keep hands, feet, hair, and clothing away from moving parts. Contact with a moving mechanism can cause entanglement, which can lead to dismemberment or death.

CAUTION: Avoid contact with the vacuum pump during or immediately after operation. Operating temperatures can range from near 200°F to over 300°F, depending on the working conditions. Contact with a hot vacuum pump can cause severe burns.

Vacuum Pump Pre-Startup Procedure

Perform the following procedure each time before you operate the vacuum pump:

- Make sure that the rotor shaft turns freely. This is especially important in cold weather to make sure that the pump is not frozen up with ice.

To verify that the rotor shaft turns freely, make sure that the ignition switch on the gas engine is in the off position, and then pull once on the starter rope.

- Check the level in the oil reservoir. Use the dipstick at the rear of the pump (on the

Table 3.1 Vacuum Pump Recommended Oils – Pump Housing*

Brand / Type	Masport and Conde Model 6	
	Cold Weather	Warm Weather
AGIP / ISO 150	Acer 150	Acer 150
BP / ISO 150	Energol CS 150	Energol CS 150
ESSO / ISO 150	Nuto 150	Nuto 150
SHELL / ISO 150	Vitrea/Tellus 150	Vitrea/Tellus 150
ELF / ISO 150	Polytellis 150	Polytelis 150

*Information on vacuum pump oils is from data available at time of printing. Specifications may change without notice.

oil reservoir) to check the oil level. Add oil, as needed, through the dipstick port. The oil in the reservoir requires periodic refilling because the pump consumes oil in the process of lubrication.

Use only OEM recommended types and brands of oil for your pump. Table 3.1 lists the manufacturer recommended lubricants for the Masport HXL3V and Conde Model 6 vacuum pump supplied with your slide-in unit. If you have difficulty obtaining manufacturer recommended oil, contact Satellite about its availability.

- Add grease at the grease fitting on the front endplate (just above the output shaft) this fitting provides grease to the bearings. It is important not to over grease the pump bearings. Use only one or two pumps on the grease gun when greasing.

► **NOTICE:** Check the oil level in the rear housing at regular intervals. Allowing the pump to run low on oil during operation will result in damage to the pump.

■ **IMPORTANT:** DO NOT over grease the pump bearings. Over greasing can cause damage to the seals.

Vacuum / Pressure Control Handle

On your Masport HXL3V and Conde Model 6 vacuum pump, locating the control handle in the center of its travel will cause the pump to operate in a neutral free flow mode.

In addition, use the control handle to select either the vacuum or pressure modes. Figure 3.7 details the handle position in relation to the pump orientation for vacuum and pressure functions. You can also observe the vacuum/pressure gauge to verify which mode you are operating in.

Vacuum Pump Operation

After performing the pre-startup

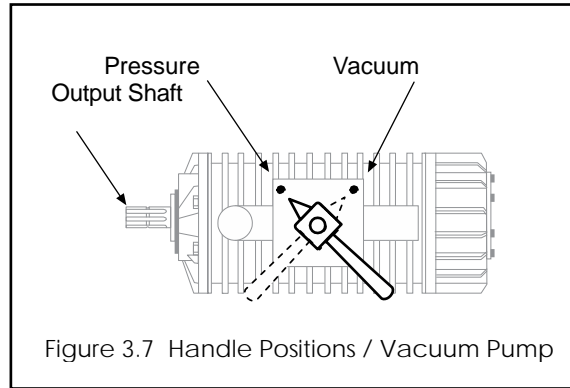

Figure 3.7 Handle Positions / Vacuum Pump

procedure, you are ready to operate your vacuum pump. The Gasport or Conde pump on your portable slide-in unit is driven by an 8 hp Honda gas engine.

Before starting the engine, position the vacuum / pressure control handle on the pump in the neutral position.

Next, move the throttle lever on the gas engine away from the SLOW position, about 1/3 of the way toward the FAST position and start the gas engine to put the pump into operation. Make sure the pump is running smoothly by listening for a pump sound with minimum vibration.

If the engine is not running fast enough, the vanes in the vacuum pump rotor will not have enough centrifugal force to keep them expanded in the rotor slots. This will result in excessive vibration as the vanes

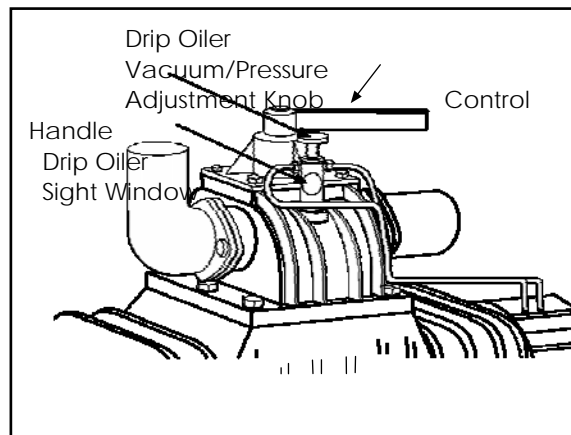

Figure 3.8 Vacuum Pump Drip Oiler & Vacuum/Pressure Control Handle

move in and out in the rotor slots, and pound against the cylinder wall. In this

case, increase the engine speed to eliminate the vacuum pump vibration and protect against vacuum pump damage.

When the pump is running, check oil flow in the drip oiler sight window to ensure that the proper lubrication is reaching the pump (Figure 3.8). The minimum recommended oiling rate is 30 drops per minute. To increase oil flow, turn the adjustment knob on the drip oiler counterclockwise. To decrease oil flow, turn the adjustment knob clockwise.

Pay close attention to the drip rate of the manual adjust drip oiler on your vacuum pump, and regulate it as necessary. Manual drip oilers require periodic checking and adjustment. In addition, readjust the drip oiler when changing oil weight in your pump.

Finally, before using the pump to load the tank, actuate the vacuum/pressure handle to be sure that the pump is operating in each mode.

► **NOTICE:** DO NOT run your vacuum pump at too slow a speed when starting it. If excessive vibration is evident, speed up the gas engine drive until the pump runs smoothly. Allowing the rotor vanes to pound against the cylinder wall by running at too slow a speed will damage the vacuum pump.

■ **IMPORTANT:** When adjusting your vacuum pump oiler, use small adjustment increments (no more than one turn at a time). This helps protect against running the pump dry due to turning the adjustment knob too lean or in the wrong direction.

► **NOTICE:** If proper oiling is not achieved within a few minutes, shut down pump and see “Trouble Shooting” section on page 31 or consult your sales representative.

Loading the Tank

With the pump in operation, use the following procedure to load the tank on your slide-in unit:

- Set the vacuum/pressure handle on the pump to the “vacuum” mode.
- Move the throttle control lever on the gas engine to about 3/4 of the way toward the FAST position (Figure 3.9). This will provide the recommended 1250 to 1300 rpm at the vacuum pump.

Moving the throttle lever all the way open will result in about 1600 rpm-s at the vacuum pump. Because this is over the 1300 rpm that the pump is rated for, the engine throttle lever must be backed down just a bit from the fill throttle position.

Making sure the throttle on the gas engine is set to provide the optimum speed for the pump requires the attentive observation of the operator. If the pump is running too slow the vanes will make a clanking sound as they move in the rotor slots. If the pump is running too fast it will overheat.

- Allow the vacuum to build to the desired level (usually about 15” Hg), and then open the valve on the suction wand and load the tank.

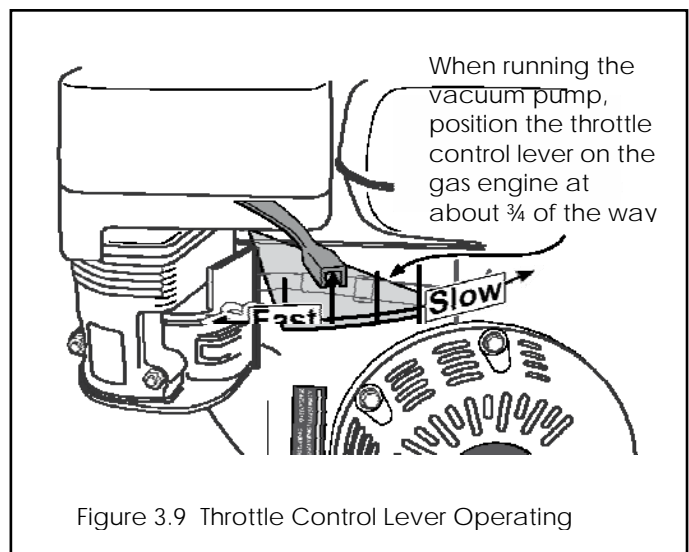

Figure 3.9 Throttle Control Lever Operating

- When the tank is full, close the fill valve and turn off the engine in order to shut down the pump

Pay close attention to the fill indicator on your tank so that you can promptly shut down your vacuum pump when the tank is full.

If for any reason you can't visually tell when the tank is full, listen for a change of sound in the vacuum pump. When the tank is full, the primary shutoff stops airflow, creating a noticeable change in the sound of the vacuum pump.

Also, in the unlikely event that the primary or secondary shutoff activates due to extreme air velocity, promptly shut down your vacuum pump. Again, a change of sound in the vacuum pump is your indicator to stop operation. This will deactivate the shutoff, at which point you can resume operation.

► **NOTICE:** DO NOT operate the pump faster than the recommended rpm. Operation above the recommended rpm will cause the pump to overheat, resulting in damage to the pump.

► **NOTICE:** Shut down your vacuum pump promptly when the tank is full. In addition, any time the primary or secondary shutoff activates, stop pump operation. At the point when either of the shut-offs activates, the pump is susceptible to over-heating if kept running. This can damage your pump.

Mechanics of Pneumatic-Transport (transfer by means of vacuum)

A vacuum, as pertaining to pumping of liquid waste, is a space with some of the air removed from it. Your vacuum pump extracts air from your vacuum tank, lowering the pressure inside of it. Atmospheric pressure pushing against the liquid does the actual loading of your vacuum tank. The liquid flows toward the

area of lower pressure created in the tank.

Vacuum is measured in inches of Mercury (in.Hg. or "Hg.). This type of measurement is based on a barometric mercury column. Standard atmospheric pressure at sea level causes the mercury in this instrument to rise 30 inches up into a glass tube with a vacuum. The dial type pressure/ vacuum gauge on your tank (Figure 3.2, page 14) gives the same in.Hg. reading as a mercury column.

Usually, 15" Hg of vacuum is sufficient to load the tank without placing undue stress on your pump. Table 3.3 lists the approximate vacuum levels required to lift water a given distance. However, these figures must be adjusted to compensate for the weight of the material and the length and diameter of suction hose being used. Effluent or seepage may often weigh more than water. Also, pumping these products through a hose induces friction. Both of these factors result in reduced lifting efficiency.

In addition, both attainable vacuum and pumping height decrease at higher altitudes. This is because atmospheric pressure decreases with height. Therefore,

Table 3.3 Vacuum Levels vs Lift Height

Vacuum in. Hg.	Lift Height (for water)
10	11'4"
15	17'
20	22'8"
21	23'8"
22	24'9"
23	26'
24	27"2"
25	28'4"
26	29'5"
27	30'6"
28	31'7"
29	32'8"
30	34'

there is less pressure at hand to load your tank. Table 3.4 lists the percentage loss of attainable vacuum for every 1000-foot rise in elevation over sea level.

While it is necessary to create enough vacuum to handle pumping height, product weight, and hose friction, it is important not to overstress the pump. Pay close attention to your pump if it is necessary to operate at a high in./Hg vacuum level. Air-cooled pumps are especially vulnerable to overheating when being operated for extended periods at high vacuum levels. Liquid cooled pumps can handle this type of operation much more readily.

In addition, operation at high in./Hg levels can also result in moisture condensation in the pump. As vacuum increases, water begins to evaporate from the surface of the liquid in the tank. Anytime that vacuum pump operation exceeds 15"Hg, water vapor can begin to show up in the air circulating in the vacuum system.

While most of this moisture collects in the oil catch muffler, some of it will also accumulate inside the pump. In order to prevent problems connected with water collecting in your vacuum pump, dry it out anytime that you notice that water has collected in the oil catch muffler.

Table 3.4 Vacuum vs Elevation

Elevation	Attainable Maximum Vacuum Level	Percentage of loss per 1,000 feet elevation
0	29.921	----
1,000	28.85	3.6%
2,000	27.82	7.0%
3,000	26.82	10.4%
4,000	25.84	13.6%
5,000	24.89	16.8%
6,000	23.98	19.9%
7,000	23.06	22.9%
8,000	22.20	25.7%
9,000	21.38	28.5%

Use the following procedure to dry the pump out:

- Unload the tank
- Open a load or dump valve (to keep from building vacuum)
- Run the pump in vacuum mode for two to five minutes

Water that is allowed to remain in your vacuum pump can diminish performance and cause serious damage. When water is present inside the pump, sludge forms. This can restrict the vanes from moving freely inside the rotor slots, reducing the efficiency of your pump. In addition, water inside your vacuum pump can freeze during cold weather operation. Attempting to operate your pump if it is frozen inside with ice will damage it.

► **NOTICE DO NOT** run your vacuum pump above the pump manufacturer's maximum continuous vacuum rating. Exceeding the maximum vacuum rating could cause damage to the pump and/or tank.

■ **IMPORTANT:** After operating your pump at high in./Hg vacuum levels, dry the pump interior out using the procedure outlined above. Water in your vacuum pump can cause sludge formation and freeze up in cold weather.

Unloading

You have two options when unloading the tank on your slide-in unit, gravity dumping or pressure dumping. Either method will effectively empty the tank, however pressure dumping increases discharge flow rate.

Begin the unloading procedure by placing the vacuum pump control handle into neutral to relieve any vacuum in the system, then use one of the following procedures.

For gravity dumping, use the following

procedure:

1. Set the control handle on the pump to the “pressure” mode.
2. Open the dump valve.

For pressure dumping, use the following procedure:

1. Place the pump into operation using the procedures in the vacuum pump pre-startup and vacuum pump operation sections on pages 16-18.
2. Set the vacuum/pressure control handle on the pump to the “pressure” mode.
3. Move the throttle control lever on the gas engine to about $\frac{3}{4}$ of the way toward the FAST position (Figure 3.9, page 18)
4. Open the pump valve to begin unloading when the pressure reaches the desired level (up to the maximum psi set on the pressure relief valve).



CAUTION: DO NOT exceed a maximum pressure of 6 psi to 8 psi with your vacuum tank. Exceeding this pressure can cause the engine to overheat, which could result in damage to equipment.

After unloading the tank, stop the gas engine, and close the dump valve. It is important to stop the engine before closing the valve to avoid pressure buildup in the system.

Wash-Down System

You will have received an OEM manual for the pressure water pump (included in your literature packet). Review and follow the operation procedures outlined in that manual. Supplementary instructions are included below.

Before operating the wash-down system on your slide-in unit, first fill the water compartment through the fresh water inlet using a hose of a smaller diameter than

inlet opening (Figure 3.10). DO NOT use a tight fitting on the inlet because this will not allow the fill port to self solvent.

When using the pressure water pump, you will need to run the gas engine in order to provide a charge to the battery. Be sure to open the valve on the suction wand (load valve), and place the vacuum pump in the vacuum mode. This will allow air to flow freely through the vacuum pump preventing it from overheating.

With the load valve and vacuum pump set as instructed above, use the following procedure to operating your pressure water pump:

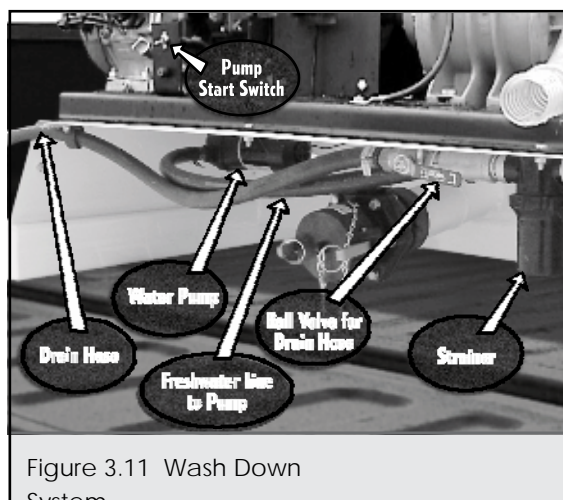

Figure 3.11 Wash Down System

- Make sure there is water in the slide-in fresh water compartment.
- Start the gas engine and run at about $\frac{3}{4}$ throttle (as per the instructions on page 18).
- Turn the pump start switch on (Figure 3.11). The pump does not require priming.
- When the water tank is empty, promptly shut the water pump off to prevent overheating.
- Shut the gas engine off to prevent overheating the vacuum pump.

Running the gas engine while using the water pump will help recharge the slide-in unit's 12 volt battery. However, the generator on the gas engine does not have the capacity to keep up with significant amperage draws from the water pump.

Additionally, the gas engine will also provide a charge to the battery when the sewage compartment is being filled (during which time the water pump is not in use). This will further add to the battery charge, however, large demands on the water pump can still leave the battery depleted.

When using the water pump frequently throughout the day it is necessary to recharge the battery using a battery charger. Usually, this can be done at the end of the day so as to avoid interfering with normal operation.

As an alternative, frequent high amperage demand on the water pump can be met by wiring the unit into the electrical system of your truck. This is a relatively straightforward process requiring the following materials:

- Number 12 automotive wiring
- A 15 amp fuse assembly
- A toggle switch assembly

Install the new circuit for the water pump by splicing into an unused auxiliary circuit under the dashboard. Most vehicles have some unused auxiliary circuits available for various vehicle options. Use a test meter to verify which line in the circuit has an amperage draw and which is the ground wire.

Route the wiring from under the dashboard to the back of the truck where the toggle switch will be located. Mount the toggle switch in a convenient location such as on the weldment stand that supports the slide-in engine and pump assembly.

Splice the fuse assembly into the wiring run so that it will be in an accessible location. Then, wire the run to the newly installed toggle switch. Finally, detach the water pump wiring from the existing switch and attach it to the new switch. The water pump will now start up when the truck ignition key is in the accessory position

and the toggle switch is in the on position.

As an added note to pump operation, during cold weather (below 32°), drain the liquid from your pressure water pump to prevent freezing and damage to the pump housing. In addition, drain all water lines and filters to protect them from freeze-up.

 **WARNING:** DO NOT use a tight fitting on the fresh water compartment fill port. This port is designed to be self venting and performs this function with the use of your fill line of a smaller diameter. Failure to allow the vent to function can result in damage to the tank and serious personal injury.

► **NOTICE:** DO NOT allow water to freeze inside the pump. Do not attempt to start the pump if water has frozen inside it. Freezing water can damage your pump. Take the truck into a warm area and allow the pump the thaw out.

Cold Weather Operation

Use the following guidelines when operating your vacuum tank in temperatures below 32°F.

Extremely cold weather can result in formation of ice inside the vacuum pump, due to residual moisture. If the pump freezes up due to ice, take the truck into a warm area and allow the pump to thaw. DO NOT use a blowtorch or other similar device to attempt to thaw a frozen vacuum pump.

Frigid temperatures could also cause the dump or load valves to freeze shut. Hot water poured over a frozen valve should loosen the ice. DO NOT use a blowtorch or similar device to thaw a frozen valve. This method could damage the valve.

Table 4.1 Lubrication Intervals

Required Lubrication	Lubrication Interval
Gas Engine - Check engine oil level	Every time before startup
Vacuum Pump – Grease front bearing at grease fitting	Per pump manufacturers recommendations or at a minimum every 4 hours of operation / daily
Vacuum Pump - Re-fill oil level in the rear housing	Per pump manufacturers recommendations or at a minimum every 4 hours of operation / daily
Reduction Gearbox - Check the oil level in the gearbox	Weekly
Gas Engine - Check transmission oil level	Weekly
Vacuum Pump - Change oil in the rear housing	To correspond with oil weight requirements for given air temperature

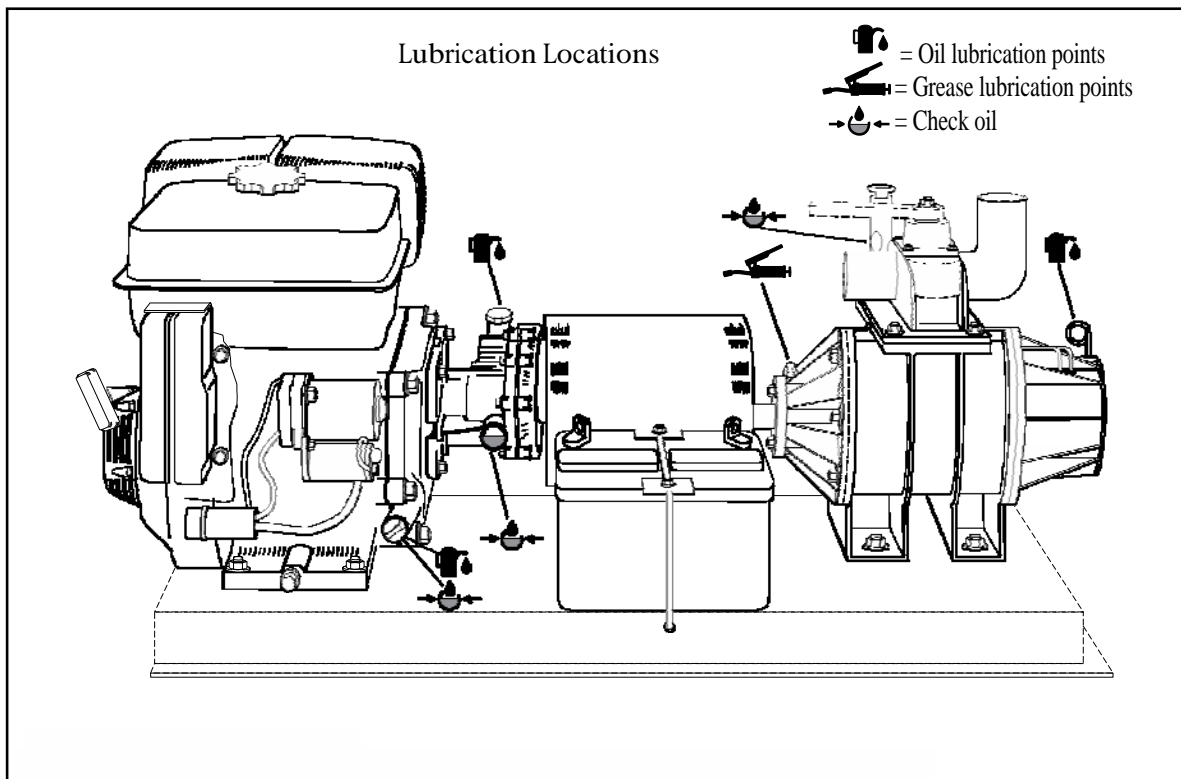

Figure 4.1 Slide-in Lubrication Locations

Note: See the maintenance subsections in this manual for specific lubricant types and lubrications intervals.

MAINTENANCE

Lubrication and Maintenance Intervals

Safe and reliable service from your Slide-in Unit depends upon a regular schedule of lubrication and maintenance. Figure 4.1 details the lubrication locations on your slide-in unit. Tables 4.1 and 4.2 list intervals for lubrication and maintenance. In addition, the following sections detail the required lubrication and maintenance for individual components.



WARNING: before performing any lubrication and maintenance, review and follow the “SAFETY PRECAUTIONS” on pages 5-7 and all safety precautions listed below.

Moisture Trap / Secondary Shut Off

Check the moisture trap daily for collected liquid. Use the easy access drain valve to empty the trap. The drain is located at the bottom of the moisture trap.

In addition to checking for liquid, inspect the ball seat and the fasteners every 2 weeks.

Check all moisture trap fasteners and tighten as necessary. Road vibration over time can loosen fasteners.

Remove the moisture trap cover to examine the ball seat for hardened rubber, nicks in the rubber, and a buildup of debris. Any of these conditions may prevent proper sealing. Clean and/or replace the ball seat as necessary.

Any time that excess liquid accumulates in the moisture trap, clean the inside of your pump. While the moisture trap helps prevent liquid from entering the pump, excess accumulation may be an indicator that some contamination has passed into the pump. Contaminates entering the

pump (including effluent) is a major cause of pump failure. See page 26 for vacuum pump cleaning procedure.

In addition, clean and/or replace the ball seat in the primary shutoff any time that excess liquid accumulates in the moisture trap. Excessive liquid in the moisture trap can often be traced to improper sealing of the ball seat in the primary.

■ **IMPORTANT:** Any time that excess liquid accumulates in the moisture trap, clean the inside of your pump. Liquid contamination that enters the pump can cause damage if you do not clean the pump shortly thereafter.

Primary Shutoff

Inspect the primary shutoff every 2 weeks to check the rubber ball seat and the tightness of all fasteners.

To inspect the ball seat, begin by first removing the cap screws that fasten the primary shutoff access lid to the portal flange on the tank (Figure 4.2). After the fasteners are removed, lift the entire shutoff assembly (which is fastened to the access lid) out of the tank be careful not to let the portal gasket fall on the ground or into the tank.

Next, remove the cap screw at the bottom of the float cage and reach up through the cage tube to remove the seat.

Next, remove the cap screw at the bottom of the float cage and reach up through the cage tube to remove the seat.

Examine the ball seat for hardened rubber, nicks in the rubber, and a buildup of debris. Any of these conditions may prevent proper sealing. Clean or replace the seat as necessary

Reassemble the primary shutoff in the reverse order. Be sure to tighten all

fasteners adequately. This is important because fasteners may become loose due to vibration. This is especially critical when driving extensive miles with an empty tank.



Wear protective gloves, eye protection, and appropriate clothing when inspecting and cleaning the primary shut off. Being a component of the vacuum system, the shut off is subjective to exposure by sewage effluent or septage. These materials may contain hazardous chemicals and bacteria, which can cause infection, injury, or even death due to contact.

■ IMPORTANT: Check the primary shutoff regularly for the condition of the ball seat and fastener tightness. Improper maintenance of the primary shutoff may allow liquid to flow into the vacuum pump, which will result in damage to the unit.

Fresh-water Compartment Coating Procedure

On Slide-in Units with a serial number before C29973 you can apply a coating to the tank interior to keep your fresh water looking good by preventing rust formation inside the tank. A coating material for this purpose, named Type A coating, can be ordered from Satellite. Use the following procedure to apply the coating to your tank interior:

- Fill the fresh water compartment with clear water to the lowest level of the sight tube.
- Add two quarts of Type A coating to the tank. Then, allow a few minutes for it to settle.
- Next, fill the tank completely with clear water and slosh around to coat all surfaces including the top of the interior.

- After you are satisfied that the tank has been completely coated, drain the tank as slowly and completely as possible.
- Allow the drained tank to set overnight, after which time the tank is ready for use.

Vacuum Pump

The OEM Operation Manual for your vacuum pump is included in the literature packet that you received with your Slide-in Unit. Review and follow the maintenance procedures outlined in that manual.

Satellite Industries furnishes the following information to provide a better understanding of your vacuum equipment. This information is intended to augment (not replace) the OEM instructions for your specific pump.

■ IMPORTANT: Follow the maintenance procedures outlined in your OEM pump manual in order to keep your warranty valid and to receive maximum service life from your pump.

Basic Vacuum Pump Maintenance

Basic maintenance on your vacuum pump involves maintaining proper oil flow, keeping the pump filled with oil, and greasing the bearings

- Using the oiler sight window, check for proper oil flow every time you operate your pump (Figure 3.8, page 17). The oiling rate (drip rate) for the Masport HXL3V or Conde Model 6 pump is 30 drops per minute.

Pay close attention to the drip rate of the manual adjust drip oiler and regulate it as necessary. Manual drip oilers require periodic checking and adjustment. See the “Vacuum Pump Operation” section, page 16, for drip oiler adjustment procedure.

Table 4.2 Maintenance Intervals
(in addition to lubrication)

Component	Required Maintenance	Maintenance Interval
Moisture Trap	Check for accumulation of	
Primary Shutoff	Clean rubber ball seat; check fastener tightness	Every 2
Moisture Trap	Clean rubber ball seat; check fastener tightness	Every 2
Mounting Brackets	Check tension on spring Month mounts	Every
Vacuum Pump	Clean pump interior	Every three months
Vacuum Pump	Clean pump exterior (to avoid	Regu
Vacuum Pump	Clean drip oiler sight glass	Periodically
Vacuum Pump	Check rotor vane wear	Per pump manufacturers recommendations (replace vanes that exceed 1/4" wear limit)

Figure 4.2 Primary Shutoff for Slide-in Units

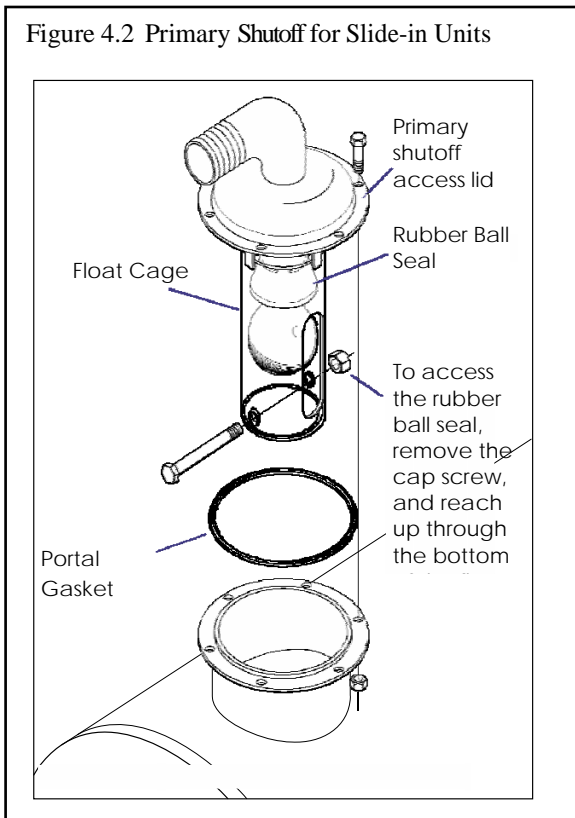
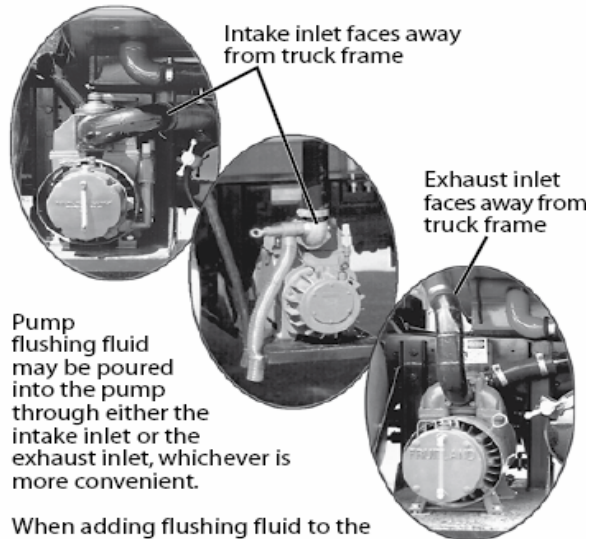

Figure 4.3 Vacuum Pump Cleaning



When adding flushing fluid to the intake inlet, place the control handle in the vacuum mode.

When adding flushing fluid to the exhaust inlet, place the control handle in the pressure mode.

After flushing fluid has been added, place the control handle in the neutral position before cycling the pump.

Also, be sure to reassemble the intake or exhaust hose (or access plug) before cycling the pump - in order to guard against inadvertent discharge of flushing fluid through the opening.

■ **IMPORTANT:** When adjusting your vacuum pump oiler, use small adjustment increments (no more than one turn at a time). This helps protect against running the pump dry due to turning the adjustment knob too lean or in the wrong direction.

- Check and refill the vacuum pump oil reservoir every 4 hours of operation or daily.

It is essential to check the oil level regularly because the pump consumes oil in the process of lubrication. Average usage of oil is approximately 1-2 quarts per 40 hours, depending upon the type of operation the pump is subjected to.

Use only OEM recommended types and brands of oil for your pump. Table 3.1, page 17, lists the manufacturer recommended lubricants for the Masport HXL3V or Conde Model 6 vacuum pump supplied with your slide-in unit. If you have difficulty obtaining manufacturer recommended oil, contact Satellite Industries about its availability.

In addition to maintaining the proper oil level in the pump, it is also necessary to use the correct oil weight depending on the air temperature in which the pump will be operating. See Table 3.1, page 16, for recommendations on oil weights and corresponding air temperature.

When changing to a different weight oil, the manual drip oiler must be checked for the proper drip rate and adjusted if necessary. See the “Vacuum Pump Operation” section, page 16, for drip oiler adjustment procedure.

- Grease the pump bearings every 4 hours of operation or daily.

It is important not to over grease the pump bearings. Use only one or two pumps on the grease gun when

greasing.

► **NOTICE:** Check the oil level in the rear housing at regular intervals. Allowing the pump to run low on oil during operation will result in damage to the pump.

► **NOTICE:** Follow the manufacturer’s recommended lubrication for your specific vacuum pump. Because of differing oil pump types and heat generation characteristics among vacuum pumps, using the incorrect oil can lead to overheating and mechanical failure.

■ **IMPORTANT:** DO NOT over grease the pump bearings. Over greasing can cause damage to the seals.

Periodic Vacuum Pump Maintenance

Other maintenance for your vacuum pump includes cleaning the exterior of the pump, cleaning of the pump interior, checking rotor vane wear, and replacing worn rotor vanes.

Cleaning the Exterior of the Vacuum Pump

Clean the mud and dirt off the exterior of your vacuum pump on a regular basis. This is especially important for air-cooled pumps that need to be clean to allow heat to radiate from them.

Cleaning Inside of the Vacuum Pump

Occasionally a small amount of liquid, dirt, or other contaminate may enter the pump, restricting the ability of the vanes to glide in the rotor slots. To prevent vane-restricting buildup in your vacuum pump, clean the inside of your pump with a flushing fluid at least every three months.

In addition, clean the inside of your pump any time that water shows up in the oil catch muffler or if excess moisture begins

to accumulate in the moisture trap. Pay attention to periodic cleaning because it will increase the life of your pump.

⚠ DANGER: Stop the truck motor, remove all persons from the truck cab, and chock the truck tires before servicing the vacuum pump. A truck that begins to roll is a crushing hazard that can lead to death.

⚠ DANGER: Make sure the gas engine on your slide-in unit is shut off before servicing the vacuum pump. Contact with a rotating mechanism can cause entanglement that can lead to death.

Use the following procedure to clean your vacuum pump:

1. Turn the gas engine off, make sure the ignition switch is turned to off, and make sure your pump is in the non-operating mode.
2. Remove the vacuum relief valve from the air line. (Figure 4.3).
3. Create a flushing fluid with a 50/50 mixture of diesel fuel and vacuum pump oil. Place the control handle on the pump in the vacuum mode, and then pour 1/2 pint of the flushing mixture directly into the pump inlet.
4. Next, turn the control handle to the neutral position to close the changeover valve.
5. Replace the vacuum relief valve.
6. Start the gas engine and run the pump at operating speed for about one minute.
7. Next, stop the gas engine, and then use the control handle to switch the pump to vacuum mode.

■ IMPORTANT: Be sure to replace the vacuum relief valve in the inlet air line

before placing the pump in the vacuum mode to expel the flushing fluid.

⚠ CAUTION: DO NOT position the control handle to the pressure mode, which would expel the fuel through the pump inlet. Incorrectly expelling the flushing fluid through an open inlet (without the vacuum relief valve replaced) could cause it to spew out at the operator.

8. Restart the gas engine, and run the pump at operating speed for about ten seconds, and then stop the engine.
9. After completing the above cleaning sequence, make sure that the ignition switch on the gas engine is in the off position, and then rotate the driveline slowly by pulling on the gas engine starter rope. Listen for a clicking sound as each rotor vane drops in its slot. If not all of the vanes are sliding freely in the pump rotor slots, repeat the above procedure until they do slide freely.

⚠ DANGER: Before rotating the driveline manually by pulling the gas engine starter rope, make sure the ignition switch is turned to off. Contact with a rotating mechanism can cause entanglement that can lead to death.

10. After completing the pump cleaning, pour 4 to 8 oz. of oil into the pump. This will require that you remove and reassemble the vacuum relief valve one more time. At this point, use Teflon tape, Teflon thread sealant, or any other good quality thread sealant for the final reassembly of the valve.

Finally, run the pump in neutral for about a minute, and then drain the oil catch muffler of the used flushing fluid. Properly dispose of the used flushing fluid. Your pump is now ready to put back into service.

► NOTICE: Add oil directly into the pump after cleaning and before putting back into

service. This is important because the cleaning procedure will rid the pump of both dirt and the necessary oil for lubrication.

Table 4.4 High Vane Wear Operating Conditions

The conditions below will reduce vane life and necessitate more frequent vane wear checking
Fine grit in intake air (e.g. sand, rust, or soil dust particles)
Many long intervals in operation*
Many intervals of high Hg. operation* (e.g. as when required to lift product a great distance).
Consistent use of pressure dumping
Running the pump dry on oil
Using the wrong oil in pump (use only manufacturer recommended oil in your pump)
Any situation in which the pump overheats
Lack of periodic pump flushing maintenance
Lack of pump flushing maintenance after water has entered the pump
Attempting to engage a pump that is frozen with ice(before thawing the pump out)

*Note: Pumps rated for continuous or heavy duty operation (such as liquid cooled pumps) can handle these conditions more readily.

Check vane wear at the interval recommended in your OEM pump manual. It is important to stay on top of vane wear because most pump manufacturers do not warrantee damage caused by vane breakage.

You may need to change your vanes more often than the manufacturer's recommendation if your pump is subjected to very heavy use. See table 4.4 for examples of heavy use factors that can shorten vane life.

When vane wear exceeds ¼" (for most pumps), the vanes must be replaced. New vanes, when bottomed in the rotor slots, will be flush with the outside diameter of the rotor. As such, vane wear is determined by measuring how deep the edge of the worn vane sits below the outside of the rotor.

In addition, if the pump volume declines significantly (i.e. it takes longer and longer to fill the tank), then the vanes probably need to be changed.

Checking the vanes the Conde vacuum pump supplied with your slide-in unit involves disassembling one of the end

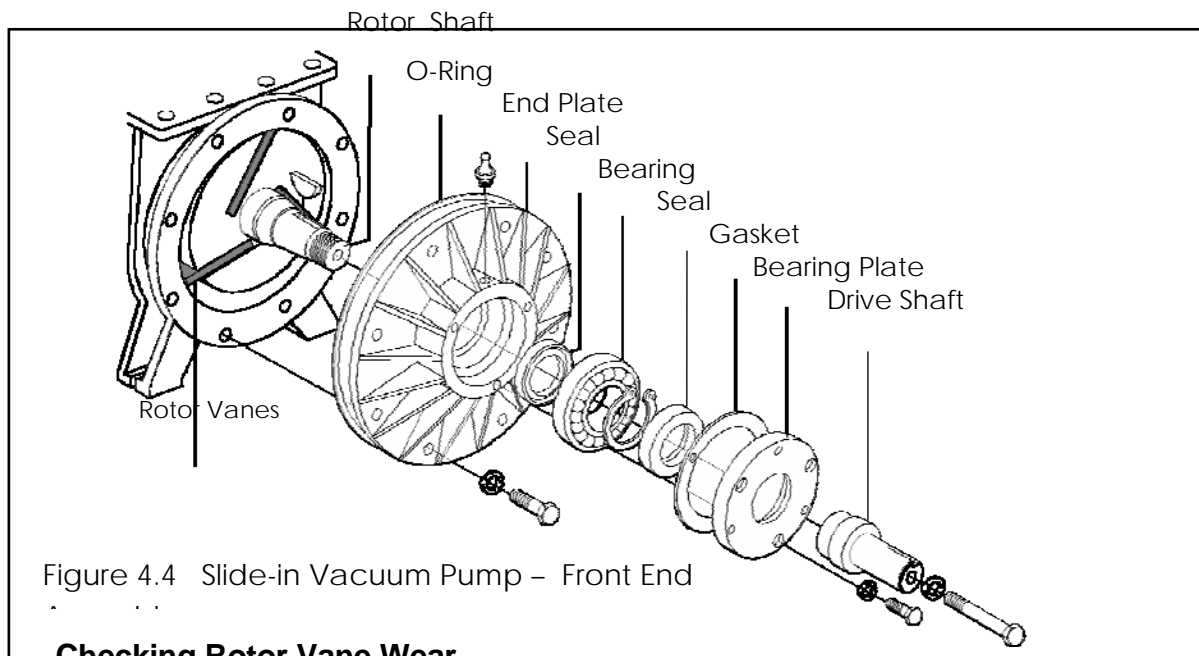

plates from the pump in order to gain access to the rotor. Because of the time this entails, it is advantageous to have a fresh set of vanes on hand before checking. Then the new vanes will be ready for installation if you need them.

Replacing Rotor Vanes

Refer to the following instructions and the pump assembly diagram in Figure 4.4 when changing the rotor vanes on your vacuum pump.

Replacing the rotor vanes requires that the pump be removed from the slide-in unit. To remove the pump, first remove the coupling guard and the inlet and outlet airline hoses. Then, unbolt the pump from the slide-in mounting stand. Remove the pump along with the pump side of the coupling. The coupling should separate freely. Place the pump on a solid work bench to ready it for changing the vanes.

⚠ WARNING: Wear protective gloves, eye protection, and appropriate clothing when working with sewage effluent or septage. These materials may contain hazardous chemicals and bacteria, which can cause infection, injury, or even death due to contact.

■ IMPORTANT: When replacing rotor vanes be sure to have replacement gaskets, O-rings, and seals on hand in case any of these items should need replacing and/or be damaged during disassembly.

■ IMPORTANT: It may be advantageous to replace gaskets, O-rings, seals, and bearings when replacing rotor vanes. Your CALUMET dealer offers a rebuild kit that includes these items.

Proper Tools for the Job

Replacing rotor vanes will require disassembly of the front end of the vacuum

pump including removing bearings and covers that may be press-fit into place. It is important to gather together the correct tools, including tools for pulling parts free from press-fits, before beginning the job.

■ IMPORTANT: Be careful not to damage bearing fits, shaft threads, or sealing surfaces by hammering, prying or gripping with pliers.

Assemble the following tools before replacing rotor vanes:

- Stiff blade putty knife
- Wrench set
- Pry bars (two blunt tip pry bars or two heavy duty, flat end, screw drivers)
- Properly sized sleeves for installing bearings
- Replacement gaskets, O-rings, and seals, or a rebuild kit
- Soft head mallet

Replacement Procedure

Use the following procedure to replace the rotor vanes in your vacuum pump:

1. Remove the coupling half attached to the drive shaft, and then unbolt the drive shaft from the rotor shaft.
 2. Remove the drive shaft from the end of the rotor shaft. If needed, tap the drive shaft with a soft mallet to help free it from the tapered rotor shaft.
 3. Remove the bolts from the bearing plate, and then remove the bearing plate from the end plate. The bearing plate should come off relatively easily, and the seal should stay with it.
- ▶ NOTICE:** Be careful to avoid damaging the seal as it slides off of the rotor shaft. In addition, be careful not to damage the gasket between the bearing plate and the end plate.
4. Unbolt the end plate, and then remove it

from the pump housing. Use the following procedure to remove the end plate:

- Use a stiff bladed putty knife to pry the cover away from the housing until there is a small gap all around.
- Once there is a big enough gap behind the end plate, use two blunt tipped pry bars or two flat head screw drivers, placed opposite each other, to pry the cover (and bearing) free of the rotor shaft.

► **NOTICE:** Be careful not to damage the O-ring between the end plate and the pump housing.

■ **IMPORTANT:** The rotor bearing will usually remain pressed into the end plate upon removal. Be careful when pulling the bearing free of the rotor shaft that the rotor does not fall down inside the pump housing. It may be necessary to provide a means of support for the rotor, such as a block of wood under the rotor shaft.

5. Remove the rotor vanes, one at a time, by first rotating the rotor so as to position a vane at the bottom of the housing. With the vane placed downward, there will be enough clearance around the rotor to grasp the vane and slide it out the end of the rotor slot.

6. After removing each vane, simply slide a new vane (that has been dipped in oil) into the rotor slot.

■ **IMPORTANT:** Always replace vanes in sets.

7. Before reassembling, inspect the rotor bore, bearings, seals, and gaskets, and replace as necessary. Seals should be soft and pliable, gaskets should not be torn, and bearings should turn freely.

8. Reassemble the vacuum pump in the reverse order of disassembly. Finally,

reassemble the vacuum pump and coupling assembly back onto the slide-in unit. Be sure to replace the coupling guard after assembly.



WARNING: Keep all shields in place. Shields and covers are designed to protect the operator from entanglement in moving parts, which can lead to serious injury or death. DO NOT remove shields from the unit except when servicing; then, replace immediately.

■ **IMPORTANT:** Be sure to use the correct size sleeve (one that fits against the inner race of the bearing) when installing the bearing back onto the rotor shaft. Use a soft mallet against the sleeve to press fit the bearing onto the shaft.

Troubleshooting Vacuum/Pressure Pumps

Reference Table 5.1 below for possible causes of Vacuum/Pressure pump problems and the most likely solutions.

Table 5.1 Trouble Shooting Vacuum/Pressure Pumps

SYMPTOM	CAUSE	SOLUTION
ROTOR DOES NOT TURN	Broken vanes (due to foreign objects or lack of lubrication).	Disassemble, clean well, change vanes, check oil level, and check float on tank.
	Frozen pump due to ice.	Take slide-in unit into warm area and thaw out.
	Frozen pump due to corrosion.	Take pump apart and replace necessary parts.
	Problem in the drive train.	Check driveline, reduction gearbox, and couplings for malfunction.
	Pump endplate bolts too tight (and in effect causing pinching of rotor).	Loosen the bolts.
PUMP IS NOT GETTING OIL	Not enough oil in housing.	Fill rear housing
	Oil weight too heavy.	Check for correct oil weight per table 3.1, page 17.
	The oil line is blocked.	Remove and clean.
	The filter on the oil pump is blocked.	Remove and clean.
	The oil pump piston is jammed on the bushing.	Remove oil pump and examine spring and piston.
	The oil pump worm gear is out of alignment.	Remove rear cover and re-align oil pump
PUMP OVERHEATS	Not enough oil in pump.	Fill oil tank.
	Oil flow rate set too lean.	Readjust the drip rate of the oiler.
	The pump isn't receiving lubrication.	Check to make sure the oil pump is working.
	Incorrect oil type or oil weight used in pump.	Replace oil in pump with OEM recommended oil.
	Rpm too high.	Reduce rpm.
	The pump operation interval is too long, or the pump is operated at excessive vacuum or pressure	Stop the pump and let it cool.
PUMP CONSUMES TOO MUCH OIL	Oiler set too rich.	Re-adjust oiler per instructions in OEM pump manual
	Oiler set light.	Replace oil with correct weight per OEM pump manual.
	Pin in drip oiler not seating.	Clean the related seat.
LITTLE OR NO VACUUM PRESSURE IN TANK	Control handle in the neutral position.	Place the control lever in the "vacuum" position.
	Primary shutoff seal leaking.	Clean or replace the seal.
	Pump rpm-s not high enough.	Run pump up to OEM recommended rpm.
	Worn vanes.	Replace vanes.
	Vacuum line between pump and tank blocked.	Remove blockage from line.
	Intake / Suction line blocked.	Remove blockage from line
	Valve, gasket, or pipes leak on tank.	Locate and repair leaks
	Vacuum or pressure relief valves leaking and/or set too low.	Repair or reset valve (WARNING: Do Not set pressure or vacuum relief valves above the maximum settings listed on pages 13 & 14 of this manual).